



BRUSHLESS
GENESE
Brushless Beyond Imagination

Backward Curved Centrifugal Fan

Features

- Compatible mounting for easier replacement.
- Conforming with multiple safety regulations in different countries, like CE, UL and CCC.
- Providing integration on the motor, control, and backward curved blade.
- Giving variable of safety protection and reducing risks of over-heat and sparks.
- Powered by high-voltage-driven technology to reduce transmission loss.
- The built-in controller is able to be connected with IoT by different control method.
- Easily applied to ventilation system, air purifier, exhaust fan, range hood.



| Fan | Rated RPM | VOLTS | Power W | Max. Flow CFM | Max. Noise dB(A) | Bearing |
|--------|-----------|---------|---------|---------------|------------------|---------|
| DCF190 | 2750 | DC 310V | 60 | 495 ± 5% | 72 | Ball |

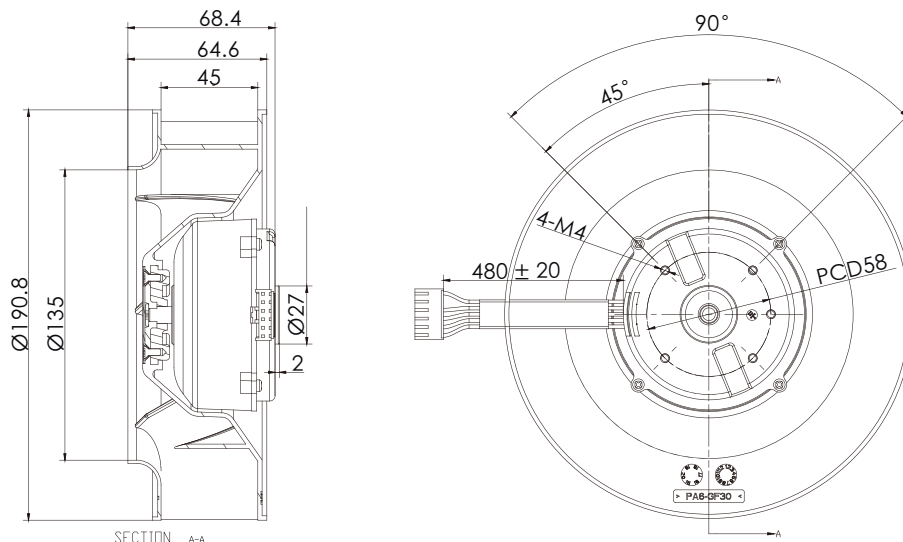
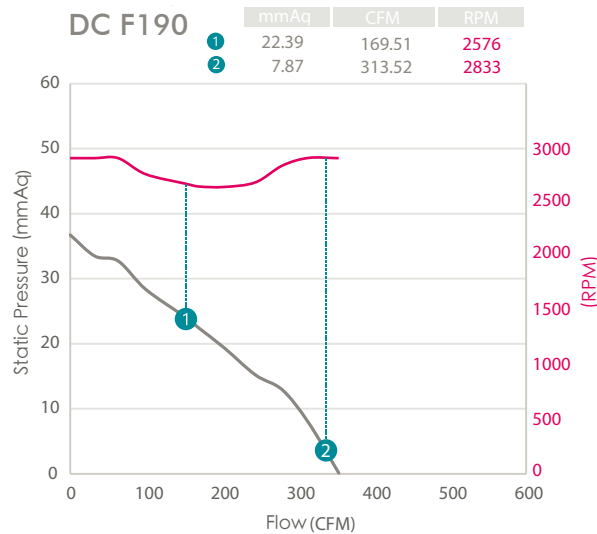

Weight: 1300g
UNIT: mm